

Isometric view of lead weathering requirements (NTS)

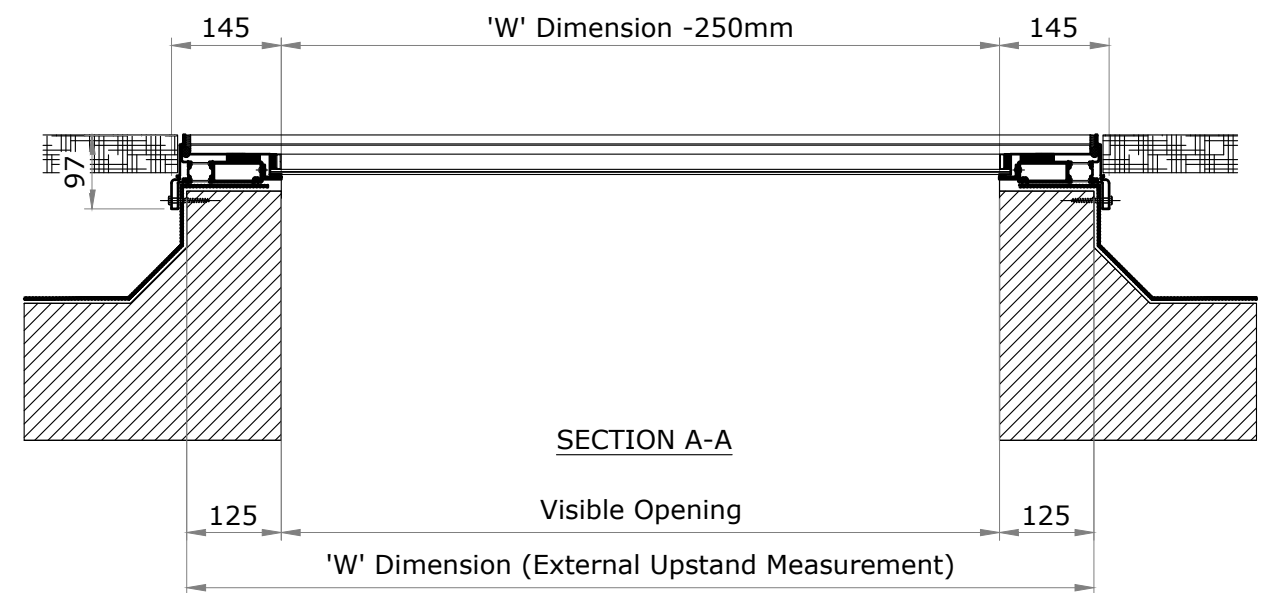

GENERAL NOTES			
1. NO DIMENSIONS ARE TO BE SCALED FROM THIS DRAWING.			
2. DISCREPANCIES IN SITE DIMENSIONS TO BE REPORTED TO NEXT GENERATION ROOFLIGHTS.			
3. ALL DIMENSIONS IN MILLIMETERS.			
4. ALL LEVELS IN METRES.			
5. THIS DRAWING REMAINS THE PROPERTY OF VISION AGI LIMITED AND MAY NOT BE COPIED, REPRODUCED OR ITS CONTENTS DIVULGED WITHOUT PRIOR WRITTEN CONSENT FROM VISION AGI LIMITED.			
Next Generation Rooflights is a trading name of Vision AGI Limited, Company No. 08429446, Registered Office: 1 Vicarage Lane, Stratford, London, E15 4HF			

Rev	Date	Init	Revision

**NEXT GENERATION ROOFLIGHTS**  
 Queens Business Park  
 Wilbraham Road  
 Fulbourn  
 Cambridge  
 CB21 5GT  
 T: 01223 792 224  
 E: sales@nextgenrooflights.co.uk  
 info@nextgenrooflights.co.uk  
 W: nextgenrooflights.co.uk



Client:

Title: External Walk On Rooflight With Wall Abutment			
Project: Rooflight			
Scales: 1:10 @ A3	Date: 01/07/22	Drawn: GSH	Chk: EW
Drg No.: EWWA-01		Rev: -	

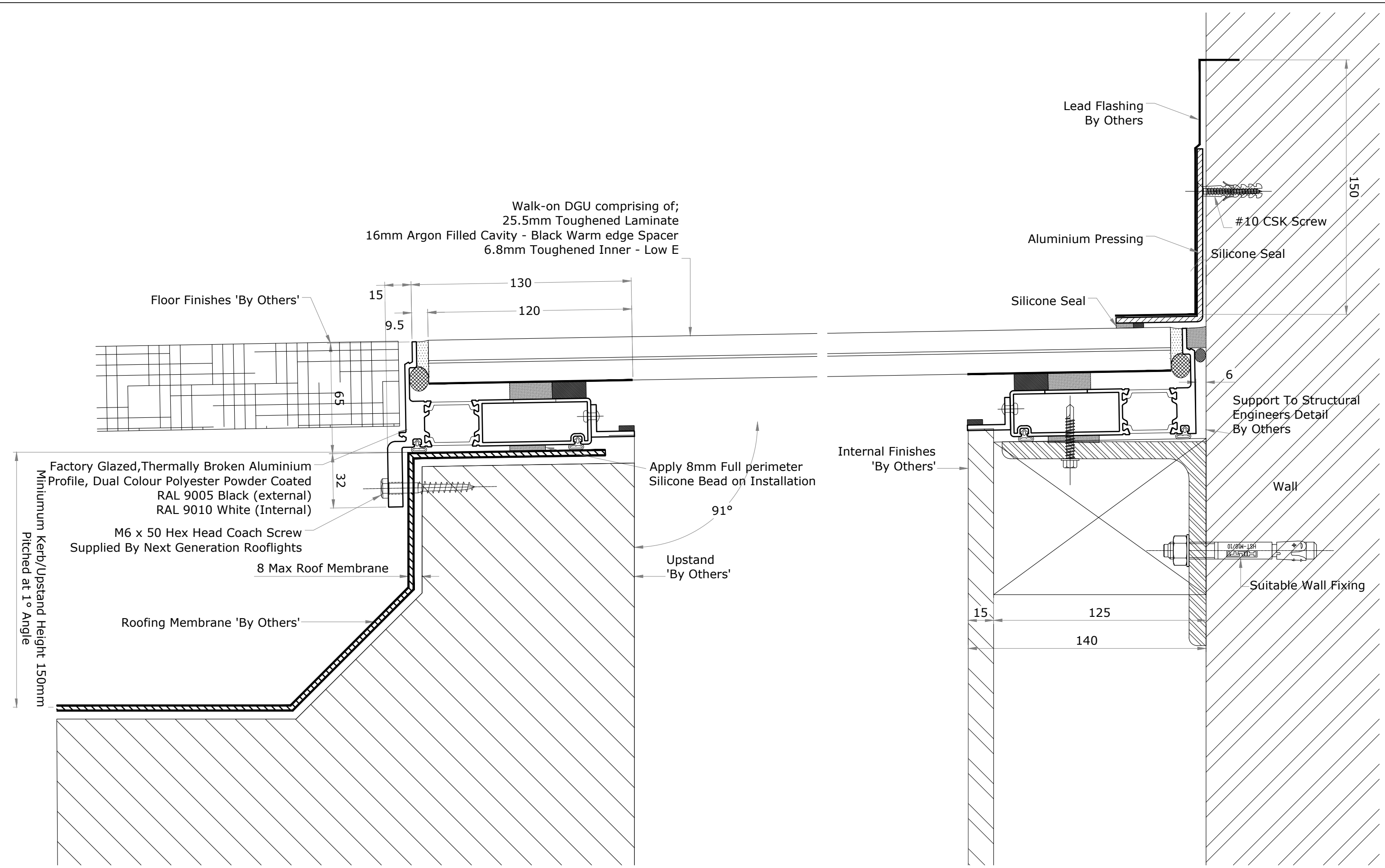

**GENERAL NOTES**

1. NO DIMENSIONS ARE TO BE SCALED FROM THIS DRAWING.
2. DISCREPANCIES IN SITE DIMENSIONS TO BE REPORTED TO NEXT GENERATION ROOFLIGHTS.
3. ALL DIMENSIONS IN MILLIMETERS.
4. ALL LEVELS IN METRES.
5. THIS DRAWING REMAINS THE PROPERTY OF VISION AGI LIMITED AND MAY NOT BE COPIED, REPRODUCED OR ITS CONTENTS DIVULGED WITHOUT PRIOR WRITTEN CONSENT FROM VISION AGI LIMITED.

Next Generation Rooflights is a trading name of Vision AGI Limited, Company No. 08429446, Registered Office: 1 Vicarage Lane, Stratford, London, E15 4HF

Rev	Date	Init	Revision

**NEXT GENERATION ROOFLIGHTS**  
 Queens Business Park  
 Wilbraham Road  
 Fulbourn  
 Cambridge  
 CB21 5GT  
 T: 01223 792 224  
 E: sales@nextgenrooflights.co.uk  
 info@nextgenrooflights.co.uk  
 W: nextgenrooflights.co.uk



Client:

<b>Title:</b> External Walk On Wall Abutment Section Detail			
<b>Project:</b> Rooflight			
<b>Scales:</b> 1:2 @ A3	<b>Date:</b> 01/07/22	<b>Drawn:</b> GSH	<b>Chk:</b> EW
<b>Drg No.:</b> EWWAD-01	<b>Rev:</b> -		