

Please note that this diagram shows the fixed flat Skylight, but is also applicable to the fixed Pyramid and Lantern Rooflights

1

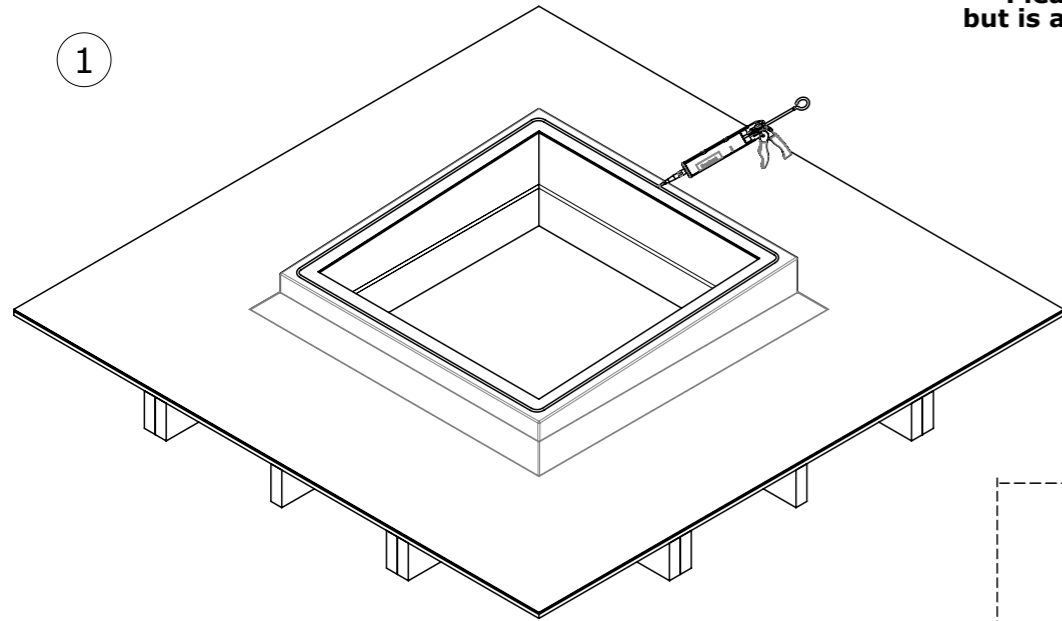

### 1. Prepare the upstand

It is important to check your upstand for any excess roofing felts/treatments or screws/nails so that the upstand is clean and flat for fixing. Apply a generous bead sealant (Compatible for your roofing membrane) (approx 8mm) centrally around the full perimeter of the upstand.

2

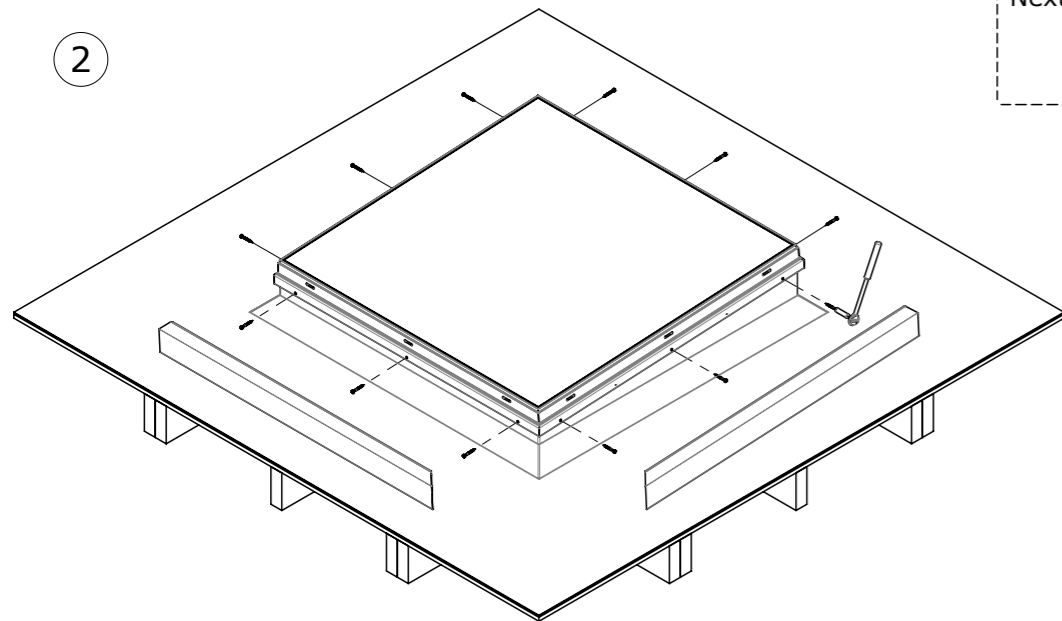

### 2. Fix the Skylight

Lift the Skylight into position compressing the pre-applied silicone. (take care not to trap your fingers!) Centralise the skylight around the upstand. Fix the Skylight by using the 6 x 50 hexagon head screws and packing shims provided. (Be careful not to over tighten!)

3

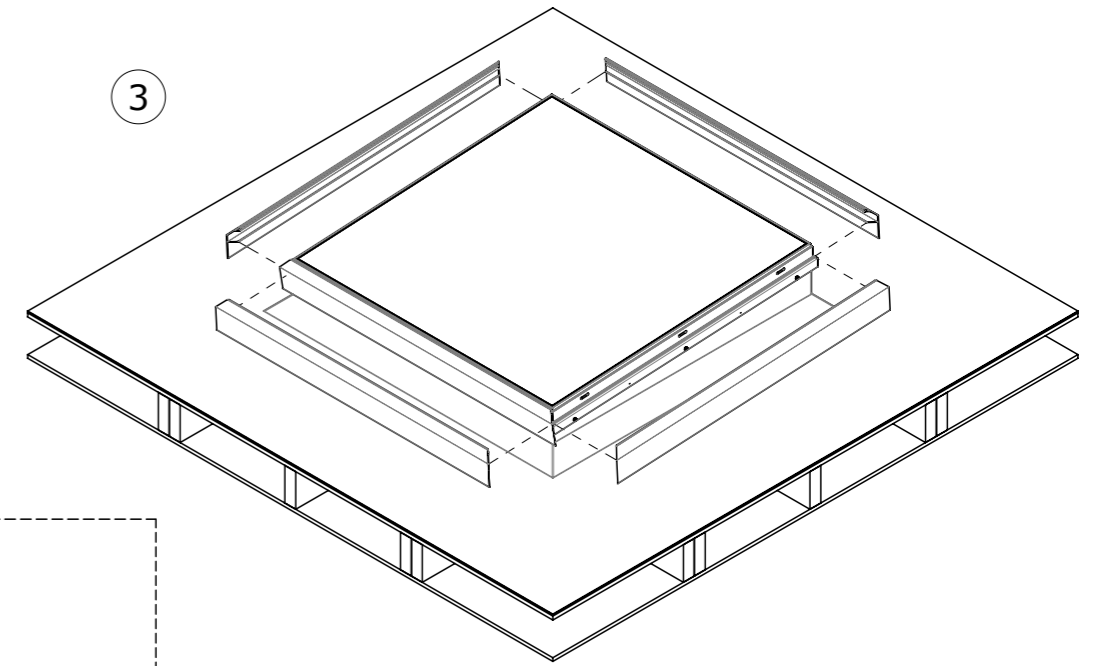

### 3. Attach the cover flashings.

Attach the cover flashings by inserting in a rotating motion. See SECTION detail. If necessary use a soft mallet to align the corners.

4

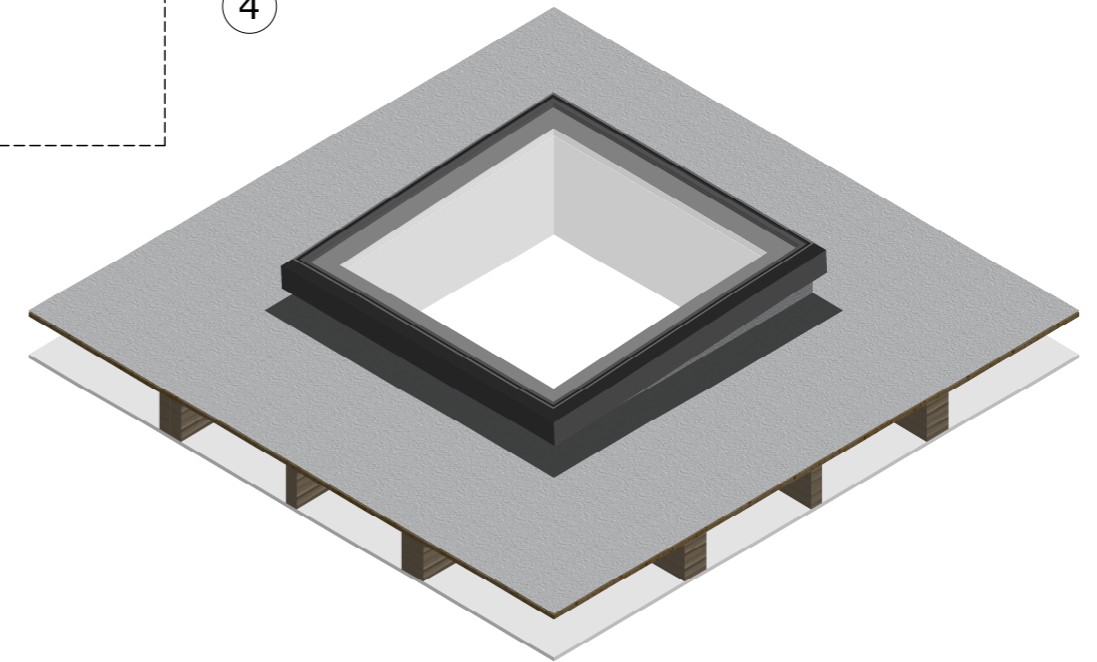

### 4. The rooflight is now installed

It is important to remove any protective films from the unit as the sunlight can react with the adhesives on the film and leave behind a residue that is difficult to remove. The internal finishes can be completed. See the SECTION detail for the standard and optional plaster finishes.

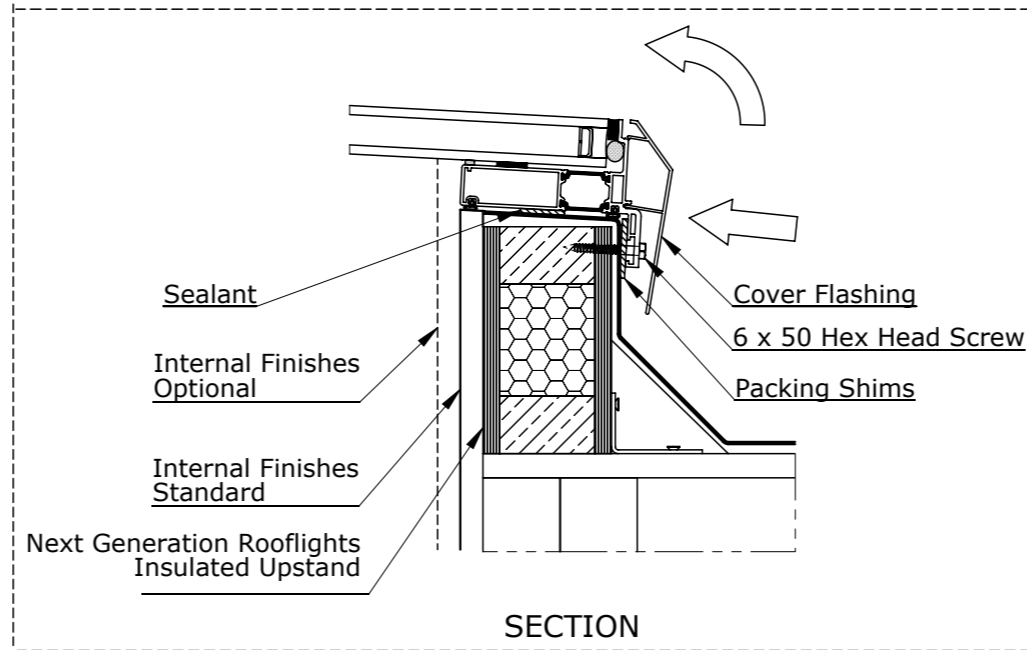

**NEXT GENERATION ROOFLIGHTS**  
Queens Business Park  
Wilbraham Road  
Fulbourn  
Cambridge  
CB21 5GT  
T: 01223 792 224  
E: sales@nextgenrooflights.co.uk  
info@nextgenrooflights.co.uk  
W: nextgenrooflights.co.uk



#### Important information. Please read and study the instructions before starting the installation.

Please ensure that the Skylight has been checked before moving it to the roof. It is important that any visible defects or problems are reported to NEXT GENERATION ROOFLIGHTS via telephone on 01245 392108. When lifting the rooflight please take into account the weight and the number of people required to safely handle the load. Plan ahead, clear the route of any obstructions and advise any site workers of when the installation is to commence. The correct way to lift the rooflight is to support the frame at quarter points keeping the rooflight flat wherever possible. Avoid sliding the rooflight over any surface (even wrapped) doing so could damage the unit. Whilst every effort has been made to ensure the accuracy of this diagram Vision AGI cannot be responsible for any loss, injury or expense resulting from errors or omissions. Rooflights should be installed by a competent person in full compliance with the relevant building regulations, good practice and applicable codes whilst adhering to any architects/engineers specific/approved design details. **Installation can now begin...**